

Pluton 19

Technical Data Sheet 2000-301

PLUTON 19 HD 2F / D6-E50x2

Twin boom high power face drill,
hydrodynamic transmission four wheel drive jumbo,
for development and cross-cutting in 8 to 50 m² sections

SERIES 2000

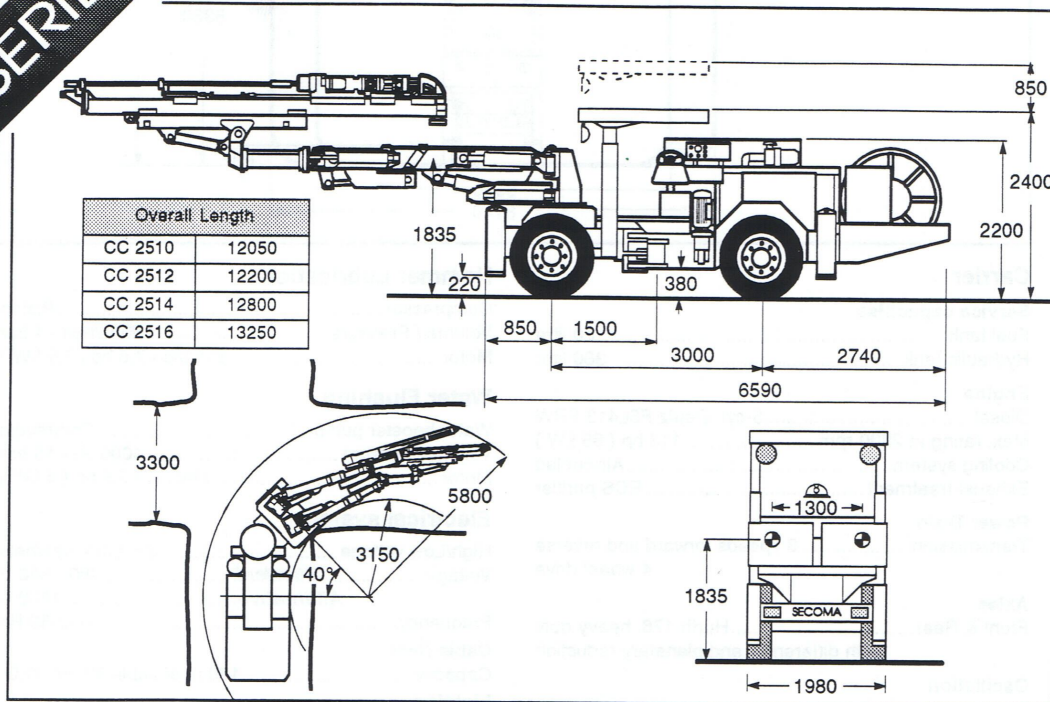

Drifters

	Standard	Alternative
Model	Hydrastar 300.....	Hydrastar 350
Standard male shank	R 32 - R 38.....	R 32 - R 38
Weight	137 kg.....	140 kg
Impact frequency.....	40-55 Hz.....	40-60 Hz
Percussion pressure	160-180 bar.....	160-200 bar
Impact power.....	14-16 kW.....	16-18 kW

Drill feeds

	Standard	Alternative
Model	Solid CC 2500...Telescopic CTEV	
Steel length	10 to 16 ft.....	7-12 or 8-14 ft
Drill steel	H 32 - H 35.....	H 32 - H 35

Booms

Model	B 26 F-OF
Type	Parallel holding
Weight (with hoses).....	1900 kg
Feed roll-over	320°
Boom extension	1200 mm
Feed extension.....	1600 mm

Hydraulic control panels

Providing auto smooth collaring
precise anti-jamming
auto return
only one control lever for thrust/percussion (full & half)
greatly reduced number of hoses

Power Packs

	Standard	Alternative
Electrical motor ...	2 x 37 kW(50 hp)	2 x 45 kW(60 hp)
Hydraulic pump	fixed displacement, radial piston	

Tramming possibilities

Tramming speed .. 1st gear max. 5 km/h
2nd gear 12 km/h
3rd gear 25 km/h
Maximum operating grade up to 35%
Maximum lateral inclination (fully turned) up to 10%
Weight, approximate 17500 kg

SECOMA